

44318/1

FIG 1 Occupies only one height unit: the new multistandard Exciter R&S®Sx800.

Exciter R&S®Sx800

Multistandard exciter for ATV and DTV

State-of-the art technology makes it possible: The new multistandard Exciter R&S®Sx800 is housed in a box of only one height unit and includes complete signal processing functionality ranging from the video/audio input signal (analog TV) and the transport stream (digital TV) to standard-compliant RF output signals.

Compact and powerful

The Exciter R&S®Sx800 (FIG 1) has been designed for use in the new Transmitter Family R&S®Nx8000 [*]. Like its predecessor R&S®Sx700, the exciter of just one height unit is based on a modular concept that ensures utmost safety of investment. It mainly consists of the input interface, mainboard and RF interface modules (FIG 2).

Input interfaces for analog or digital TV

The exciter is equipped with the corresponding interfaces depending on the relevant operating mode – ATV or DTV. You can easily upgrade the exciter from analog to digital standard at any time, since the required software has already been installed.

The input interface for ATV converts the video and audio signals required for further internal processing into digital signals. It optionally handles the NICAM signal processing and codes and modulates the NICAM sound subcarrier. The operating modes “analog audio”, “NICAM DATA 728” and “NICAM sub-carrier” are supported.

For DTV, the R&S®Sx800 with four ASI inputs (DVB-T/-H) or two inputs in line with SMPTE-310M (ATSC) can be universally used for all operating modes of the following standards: DVB-T/-H and ATSC (including ATSC DX for SFN).

With DTV, the input interface monitors the applied signals with respect to packet synchronization and data rate. The input data buffer eliminates jitter and frequency offsets of the distribution network. In multifrequency networks (MFNs), the input data rate is adapted to the selected DVB-T mode including

Exciter A

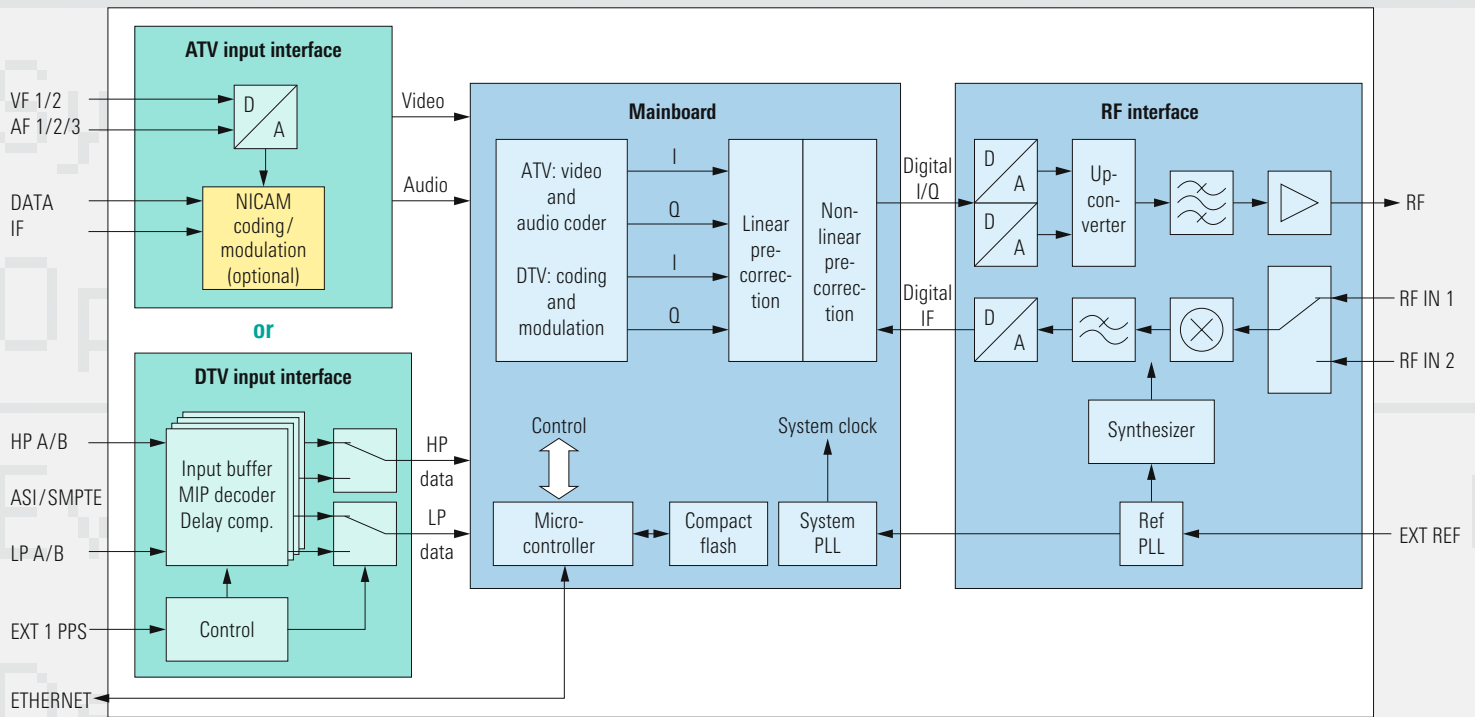

FIG 2 Structure of the multistandard Exciter R&S®Sx800.

	Manual	Selector	TPS
Constellation	QPSK	Man	QPSK
FFT Length	2 K	TPS	2 K
Hierarchy	alpha=1	Man	alpha=2
Guard Interval	1/4	Man	1/4
Code Rate	1/2		

Edit: Manual	
1/4	
1/8	
1/16	
1/32	

FIG 3 Operation of exciter via the R&S NetCCU®800.

Condensed data of the R&S®SX800

ATV standards	B/G, D/K, M/N, I
Color transmission	PAL, SECAM, NTSC
Sound transmission	IRT dual sound, FM single sound, FM single sound with NICAM 728 (optional), BTSC
DTV standards	DVB-T/H in line with EN 300 744 ATSC (8VSB) in line with Doc.A/53 FCC band I, III, IV, V
Frequency range	
Output power	ATV: +20 dBm sync peak power DTV: +13 dBm RMS

- the necessary PCR (program clock reference) correction. Every path has its own TS 101 191-compliant MIP decoder that is able to automatically recognize the operating mode. When operated in single-frequency networks (SFNs), the MIP decoders also provide information on the time-relevant synchronization of input signals and thus allow automatic and seamless input signal switching. Redundant input signals can be applied but the output signal will not be interrupted during switchover.

Signal processing on the mainboard

With ATV selected, the mainboard processes the signals digitized by the input interface in accordance with the relevant TV standard. Digital signal processing ensures highest stability and thus allows easy precorrection of transmit signals.

With DTV selected, coding and modulation are in line with EN 300 744 (DVB-T/H) or Doc. A/53 FCC (ATSC). Digital filters and algorithms with relevant resolution ensure top quality of the generated I/Q signals applied to the subsequent precorrector. Linear precorrection compensates group delay and frequency response caused by power filters in the RF path, for example. Nonlinear precorrection compensates distortion products caused in the amplifiers.

With digital precorrection applied here, you can reproduce the results at any time. An automatic/adaptive precorrection function can be supplied as an option for digital operation.

Special features of the Exciter R&S®Sx800

- ◆ Suitable for use in single-frequency and multifrequency networks
- ◆ Hierarchical modulation
- ◆ Seamless input switching
- ◆ MIP monitoring
- ◆ All ASI modes
- ◆ SMPT-310M
- ◆ DVB-H, DVB-T, ATSC
- ◆ All analog TV standards (except for L)
- ◆ Integrated linear and nonlinear precorrection
- ◆ Optional automatic precorrection (DTV), NICAM

RF interfaces

The RF interface converts digital I/Q signals into analog baseband signals. The modulator that follows generates the readily modulated signal via double conversion. This signal is then filtered and amplified. Since direct modulation and conversion are coupled, adjustments are no longer required when the frequency is changed. Since switchable attenuator pads are provided at the output, you can optimally adapt the output level to subsequent amplifiers.

The synthesizer, which can of course be coupled to an external reference frequency, provides the required mixer frequencies. The high quality of the reference oscillator ensures that the frequency stability in the SFNs remains unchanged even if the external reference fails. The RF interface optionally contains the demodulator path, which processes the amplified or filtered RF signal for signal analysis in case of automatic/adaptive precorrection. The exciter has two inputs at which the signals can be tapped ahead of or after the power filter.

Control

A powerful microcontroller controls and configures the R&S®Sx800. It initializes the hardware from a compact flash memory that comprises the complete software and firmware as well as all settings. This concept simplifies the configuration of a replacing unit: The memory is taken from the exciter to be replaced and is inserted into the replacing unit. The replacing unit runs with the identical software version and the same settings after switch-on.

The controller in the transmitter communicates with the R&S NetCCU®800 via Ethernet interfaces and, if required, with a local PC. In the transmitter, the exciter can be operated via Ethernet using the CCU (FIG 3). Alternatively, local and remote control is possible via the web browser of a PC. A Java-based web server is available in the exciter. It makes software installations on the PC superfluous.

Cornelius Heinemann

More information and data sheet at
www.rohde-schwarz.com

REFERENCES

- [*] UHF TV Transmitter R&S®NH / NV8200: Air-cooled UHF/VHF TV transmitters for the medium-power segment. News from Rohde & Schwarz (2005) No. 185, pp 40–42