

DTXPRO-800U DIGITAL TRANSMITTER

INTEGRATED MODULATOR
and TRANSMITTER
REMOTE CONTROL



INTRODUCTION

The DTXPRO-800U transmitter is an integrated transmission system. Included in a 24 RU rack is a modulator, power amplifier, mask filter, and standard accessories. The DTXPRO-800U is tested to FCC specifications.

The modulator used in this assembly is the DXDPRO-10U. The DXDPRO-10U is a UHF 8vsb BROADBAND MODULATOR with adaptive linear and nonlinear correction controllable via an Ethernet IP connection. Many additional features are included in this basic modulator such as TRANSMITTER REMOTE CONTROL and STATUS MONITORING, GPS RECEIVER, ASI or SMPTE 310M, and FAULT NOTIFICATION VIA EMAIL. This unit will operate with 110 VAC or any 48 VDC TELECOM back up system in case AC Mains fail. Back up DC supply is not supplied in this package.

The MFA2PAU provides power amplification to achieve the desired power output level to comply with FCC license requirements. LD MOS 50 VOLT DEVICE TECHNOLOGY is used throughout the HPA section for state-of-the-art performance. This unit is wired to operate off 220V AC

An FCC Compliant STRINGENT MASK FILTER is supplied and is built into the rack. Additional components are included to sample forward and reflected power as well as samples for the adaptive linear and nonlinear corrector. The systems HPA is protected from antenna or filter faults by an ISOLATOR built into the HPA. Any faults in the filters or antenna will be detected by the onboard protection circuits. This transmitter includes a LOW PASS FILTER for additional harmonic suppression in the GPS Bands.

Pineapple Technology, Inc. warrants the DTXPRO LINE of transmitter products for 2 years from ship date. Extended warranty is available for an additional 5 years. Contact PTI sales for details.



PINEAPPLE TECHNOLOGY, INC.

www.ptibroadcast.com

DTXPRO-800U DIGITAL TRANSMITTER

INTEGRATED MODULATOR and TRANSMITTER REMOTE CONTROL

TRANSMITTER GENERAL SPECIFICATIONS

FCC COMPLIANT APPLICABLE SERVICE REQUIREMENTS
STANDARDS ATSC (8vsb), A/53, ASI
MODULATION 8 LEVEL VSB TRELLIS ATSC COMPLIANT
ADAPTIVE CORRECTION... LINEAR & NON LINEAR CORRECTION
TS OPTIONS ASI OR SMPTE-310M
CLOCK STABILITY <2ppm (GPS LOCK AVAILABLE)
CONTROL ETHERNET WITH WEB PAGE GUI
ACCESS PROTECTION THREE-LEVEL PASSWORD PROTECTION
KEY PERFORMANCE TEST SHOULDER LEVELS -62 dB TYPICAL
MER/SNR -35 dB TYPICAL
FREQUENCY RANGE *470-810 MHz
RF OUTPUT POWER 400-800 WATTS

MASK FILTER 6 POLE STRINGENT FCC MASK
LOW PASS FILTER ADDITIONAL HARMONIC SUPPRESSION
FOR GPS BAND
PRIMARY POWER 110 VAC 50/60 CYCLE. THE DXDPRO-10U
WILL ALSO OPERATE OFF 48 VDC IF
AVAILABLE.
REMOTE CONTROL 12 STATUS AND 12 ALARM OPTIONS
ASSEMBLED RACK 19 INCH 24 RU RACK
WIDTH 22 INCHES (559 mm)
HEIGHT 48 INCHES (1219 mm)
DEPTH 32 INCHES (813 mm)
WEIGHT < 175 LBS (80 Kg)

**Frequency range limited by external equipment, i.e., filters and isolators. This can be modified and or returned if it becomes necessary to change channels.*

DTXPRO-800U BLOCK DIAGRAM

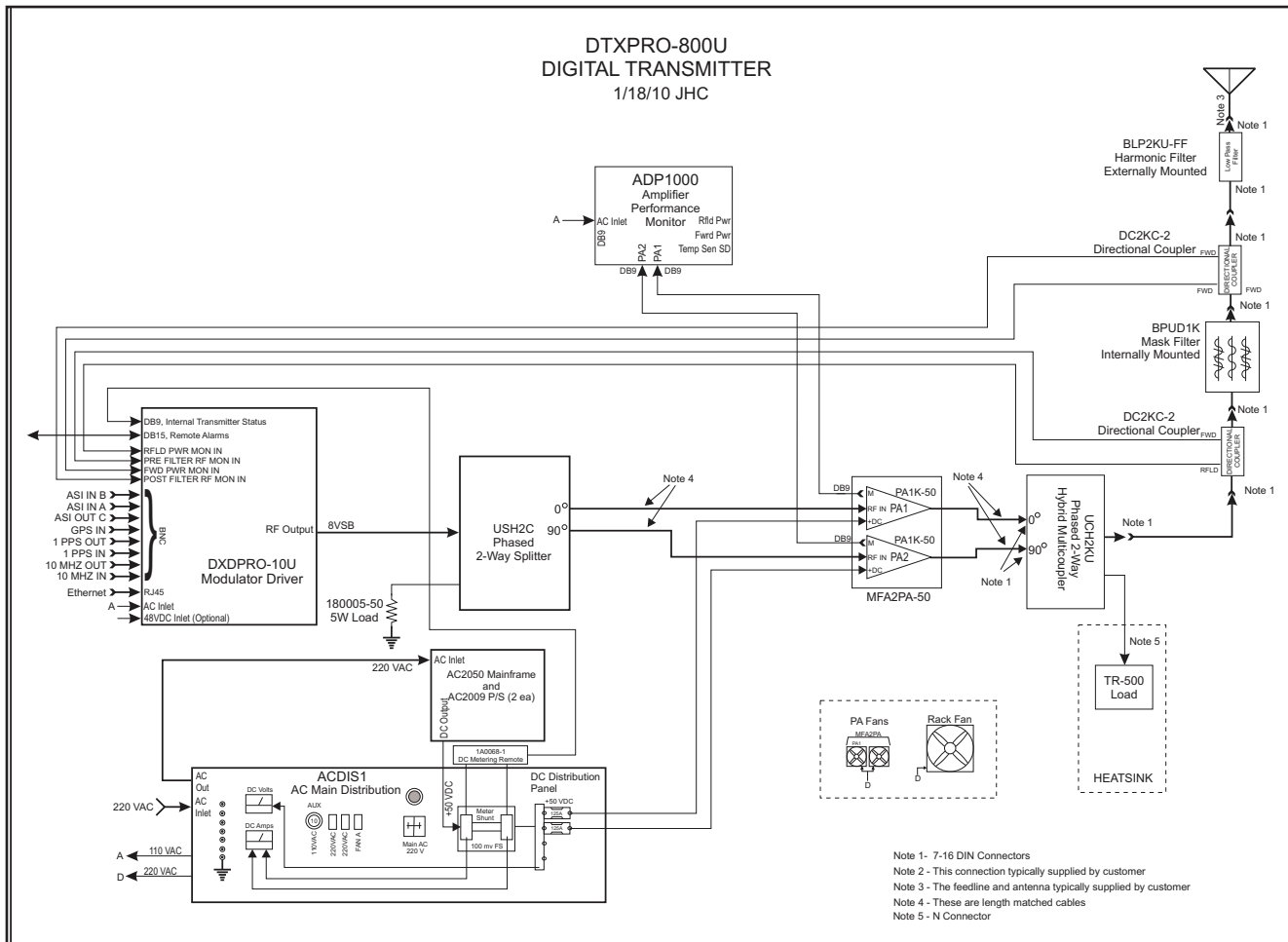

DTXPRO-800U DIGITAL TRANSMITTER

INTEGRATED MODULATOR
and TRANSMITTER
REMOTE CONTROL

MODULATOR DXDPRO-10U FRONT PANEL

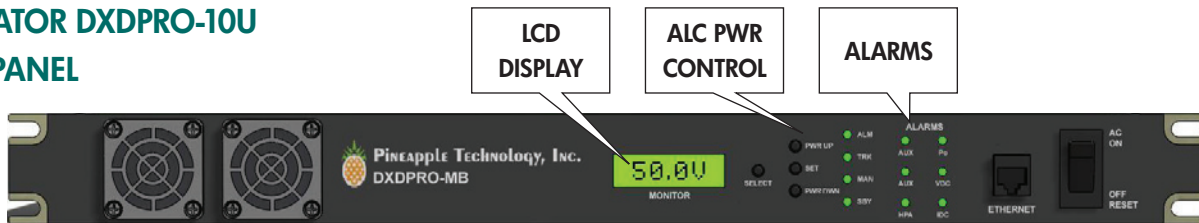

RECEIVER DISPLAY: The receiver control and display panel is used to show status of the receiver and allows selection of desired receive channel. The receiver signal strength is displayed as well as LOCK and POWER status.

LCD DISPLAY: The LCD DISPLAY provides selected transmitter test data by depressing the SELECT switch located on the right side. Some of the options include the following;

1. RF POWER OUTPUT LEVEL
2. REFLECTED POWER LEVEL
3. DC SUPPLY VOLTAGE
4. DC CURRENT

ALC CONTROL PANEL: The ALC section serves two important functions.

1. Provides a means for raising or lowering transmitter power level.
2. Once the desired power level is reached, the set switch places the ALC circuit in the TRACK MODE. In the TRACK MODE THE OUTPUT LEVEL IS CONSTANT.

ALARM PANEL: The alarm LEDs indicates status of key alarms. Key alarms include the following;

1. LOW OUTPUT POWERNORMAL (GREEN) FAULT (RED) <85 %
2. HIGH REFLECTED POWER.....NORMAL (GREEN) FAULT (RED) >20 %
3. 48 VDC SUPPLY.....NORMAL (GREEN) FAULT (RED) <42 v
4. AC MAIN VOLTAGE*NORMAL (GREEN) FAULT (RED) <50 %
5. AMBIENT TEMPERTURENORMAL (GREEN) FAULT (RED) >40 c
6. HEAT SINK TEMPERTURENORMAL (GREEN) FAULT (RED) >62 c

*48 VDC backup power required

REAR PANEL

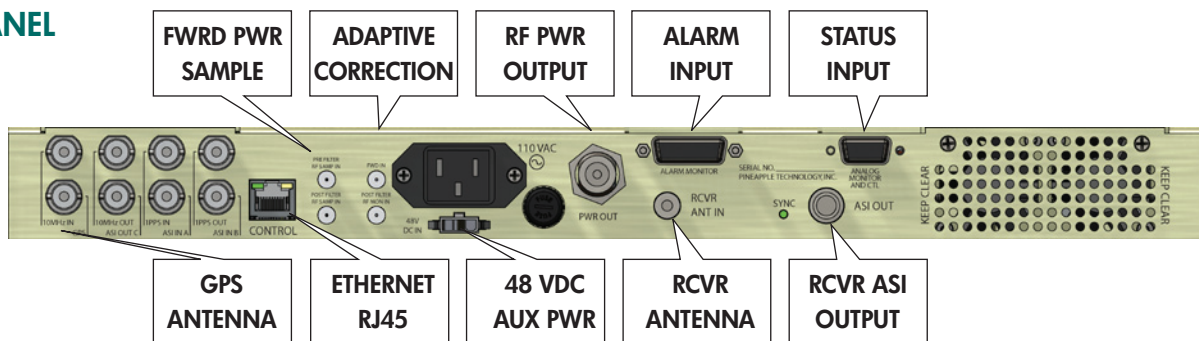

Mating Connectors

BNC JACK 75 OHMSGPS, ASI IN, SMPTE-310
 ETHERNETRJ-45
 RF MONITORINGSMA JACK
 ADAPTIVE SIGNAL.....SMA JACK
 RF OUTPUT.....TYPE N JACK

RECEIVER ANTENNA.....TYPE F JACK
 ALARM INPUTS.....DB 15 JACK
 ANALOG STATUSDB 9 JACK
 48 VDC INPUT.....MOLEX 3P

DTXPRO-800U DIGITAL TRANSMITTER

INTEGRATED MODULATOR
and TRANSMITTER
REMOTE CONTROL

WEB PAGE GUI

Web Page Commands

- Click and drag (XMTR ICON) to lower 1/2 page to see status and alarms
- Click and drag (LINEAR ICON) to lower 1/2 page to control linear correction
- Click and drag (NONLINEAR ICON) to lower 1/2 page to control nonlinear functions
- Click and drag (MUTE ICON) to lower 1/2 of page to mute and un mute xmtr
- Click and drag (RF OUTPUT) to change the output level from modulator
- Click and drag (BELL ICON) to view modulator alarms
- Click and drag (GPS ICON) to setup GPS receiver
- Click and drag (SWITCHING ICON) to select input port for ASI or SMPTE-310

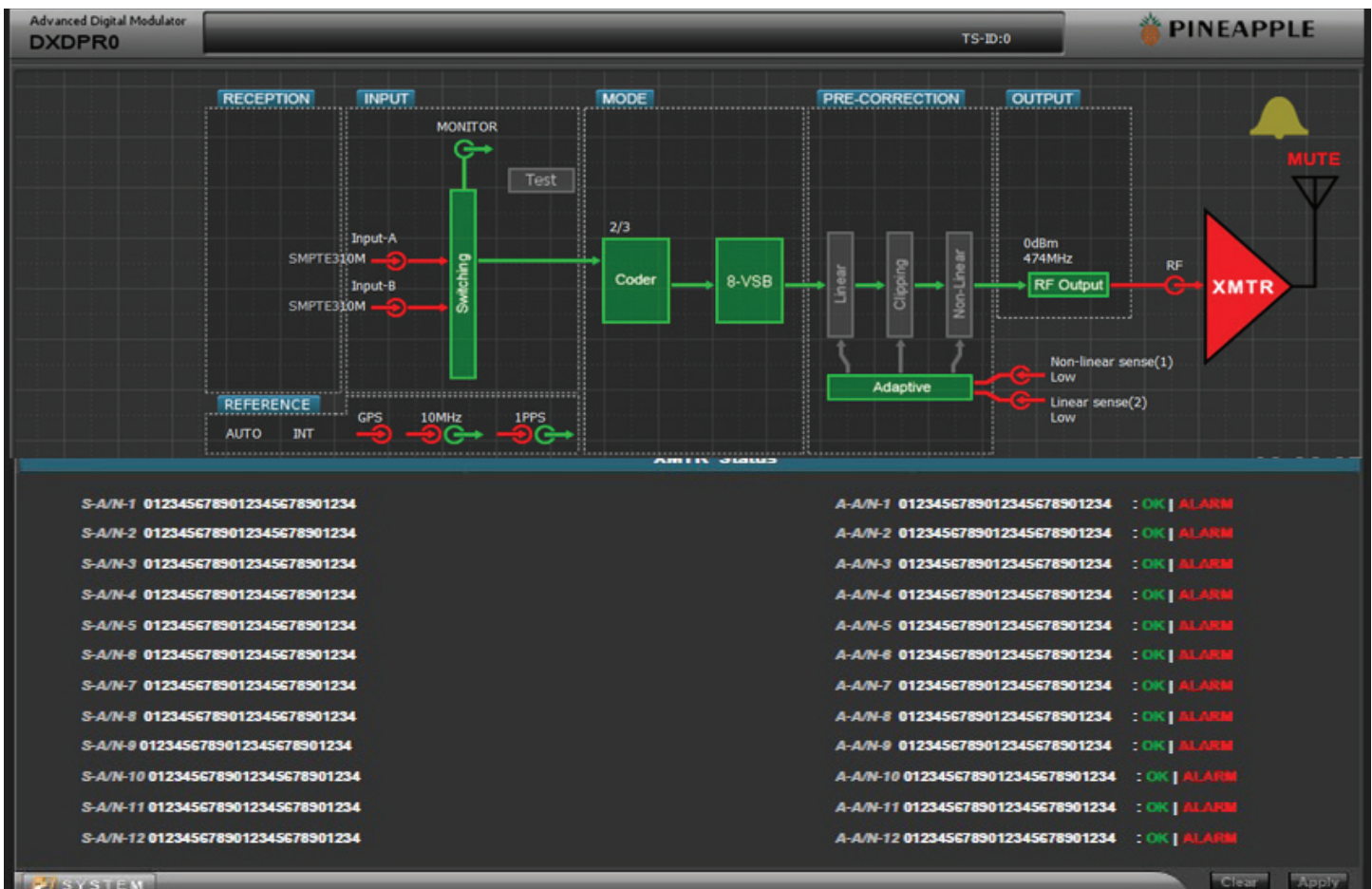

MFA2PAU FINAL AMPLIFIER

The final amplifier Mainframe includes the following items:

1. 2ea PA1K-50
2. PA STATUS PANEL
3. COOLING FANS AND HEAT SINK
4. PA CURRENT STATUS MONITORING VIA DB-9
5. GAIN & PHASE MATCHING MODULE

BLOCK DIAGRAM MFA2PAU

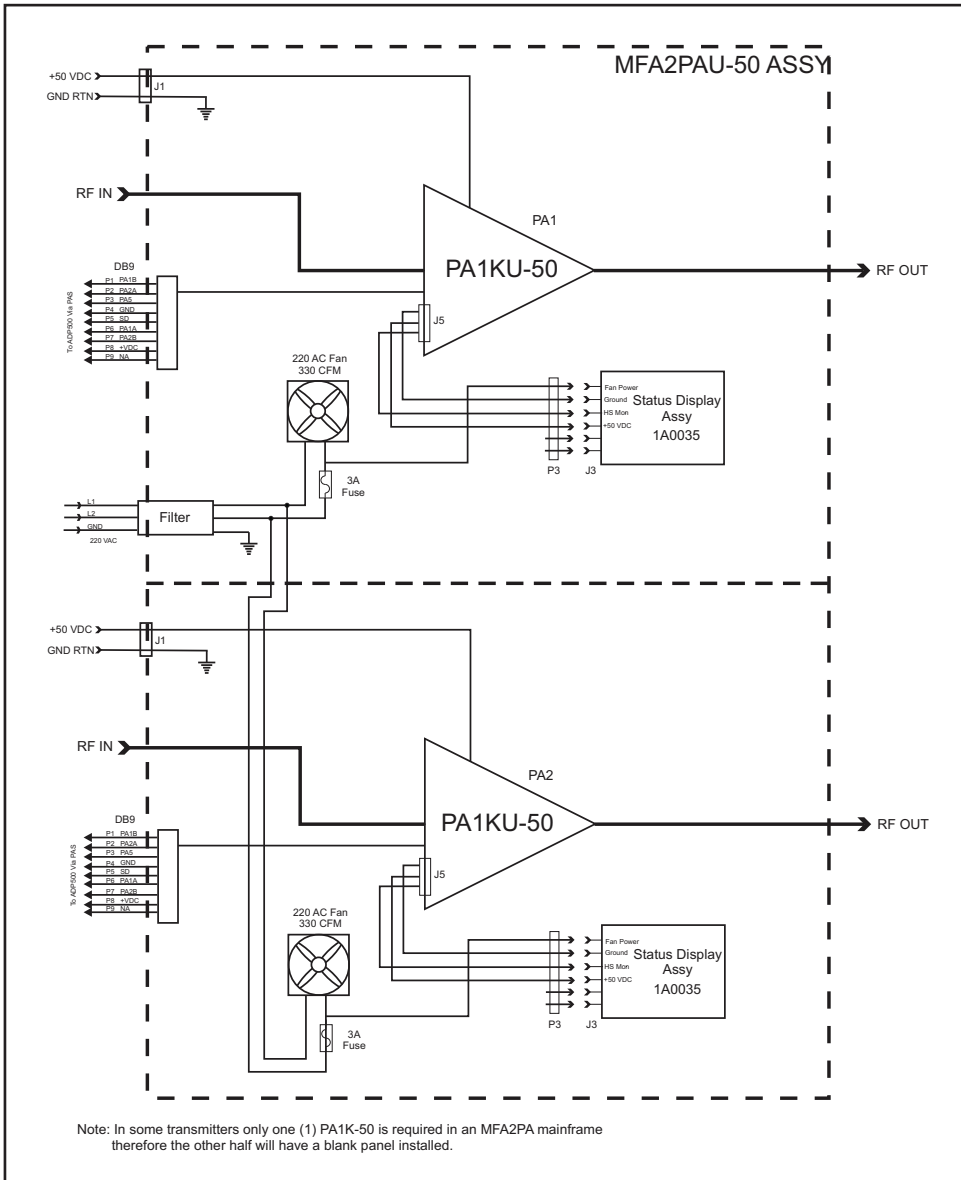

PINEAPPLE TECHNOLOGY, INC.

Web site: www.ptibroadcast.com

4231 Pacific Street, Suite 27, Rocklin, CA 95677

(916) 652-1116 . Fax: (916) 652-1161
U.S. Toll-free (888) 888-8229

ASSEMBLED IN U.S.A. Some products include foreign components.
Information contained herein is subject to change without notice.
© 2010 Pineapple Technology, Inc. All Rights Reserved. Rev. 11/14/2010