

DTXPRO-2.3KVH UHF DIGITAL TRANSMITTER

BUILT IN DIGITAL MODULATOR
and TRANSMITTER REMOTE
CONTROL



INTRODUCTION

The DTXPRO-2.3KVH transmitter is an integrated transmission system. Included in a 40 RU rack is a modulator, power amplifier, and combiner. The mask filter, low pass filter, and directional couplers are mounted external to the 40 RU rack. The DTXPRO-2.3KVH is tested to FCC specifications.

The modulator used in this assembly is the DXDPRO-10VH. The DXDPRO-10VH is a UHF 8vsb BROADBAND MODULATOR with adaptive linear and nonlinear correction controllable via an Ethernet IP connection. Many additional features are included in this basic modulator such as TRANSMITTER REMOTE CONTROL and STATUS MONITORING, GPS RECEIVER, ASI or SMPTE 310M, and FAULT NOTIFICATION VIA EMAIL. This unit will operate with 110 VAC or any 48 VDC TELECOMS back up system in case AC Mains fail. Back up DC supply is not supplied in this package.

The MFA2PAH amplifier assemblies provide power amplification to achieve the desired power output level to comply with FCC license requirements. LD MOS 50 VOLT DEVICE TECHNOLOGY is used throughout the HPA section for state-of-the-art performance. This unit is wired to operate off 220V AC single phase.

An FCC Compliant STRINGENT MASK FILTER is supplied. Additional components are included to sample forward and reflected power as well as samples for the adaptive linear and nonlinear corrector. The transmitters HPA are protected from antenna or filter faults by ISOLATORS built into the HPA. Any faults in the filters or antenna will be detected by the onboard protection circuits. This transmitter includes a LOW PASS FILTER for additional harmonic suppression in the GPS Bands. Pineapple Technology, Inc. warrants the DTXPRO LINE of transmitter products for 2 years from ship date.



PINEAPPLE TECHNOLOGY, INC.

www.ptibroadcast.com

DTXPRO-2.3KVH UHF DIGITAL TRANSMITTER

BUILT IN DIGITAL MODULATOR and TRANSMITTER REMOTE CONTROL

TRANSMITTER GENERAL SPECIFICATIONS

FCC COMPLIANT APPLICABLE SERVICE REQUIREMENTS
STANDARDS ATSC (8vsb), A/53, ASI
MODULATION 8 LEVEL VSB TRELLIS ATSC COMPLIANT
ADAPTIVE CORRECTION... LINEAR & NON LINEAR CORRECTION
TS OPTIONS ASI OR SMPTE-310M
CLOCK STABILITY <2ppm (GPS LOCK AVAILABLE)
CONTROL ETHERNET WITH WEB PAGE GUI
ACCESS PROTECTION.... THREE-LEVEL PASSWORD PROTECTION
KEY PERFORMANCE TEST SHOULDER LEVELS -62 dB TYPICAL
MER/SNR -35 dB TYPICAL
FREQUENCY RANGE..... *174-220 MHz
RF OUTPUT POWER 1.6 KW – 2.3 KW AVG. DIGITAL POWER
MASK FILTER..... 6 POLE STRINGENT FCC MASK

LOW PASS FILTER ADDITIONAL HARMONIC SUPPRESSION
FOR GPS BAND
PRIMARY POWER..... 220 VAC SINGLE PHASE 50/60 CYCLE
THE DXDPRO-10U WILL ALSO OPERATE
OFF 48 VDC IF AVAILABLE. OPTIONAL
220 VAC 3-PHASE POWER PACKAGE IS
AVAILABLE ON REQUEST.
REMOTE CONTROL 12 STATUS AND 12 ALARM OPTIONS
ASSEMBLED RACK 19 INCH 40 RU RACK
WIDTH 23 INCHES (584 mm)
HEIGHT 89 INCHES (1981 mm)
DEPTH..... 32 INCHES (813 mm)
WEIGHT..... < 350 LBS (159 Kg)

**Frequency range limited by external equipment, i.e., filters and isolators. This can be modified and or returned if it becomes necessary to change channels.*

DTXPRO-2.3KVH BLOCK DIAGRAM

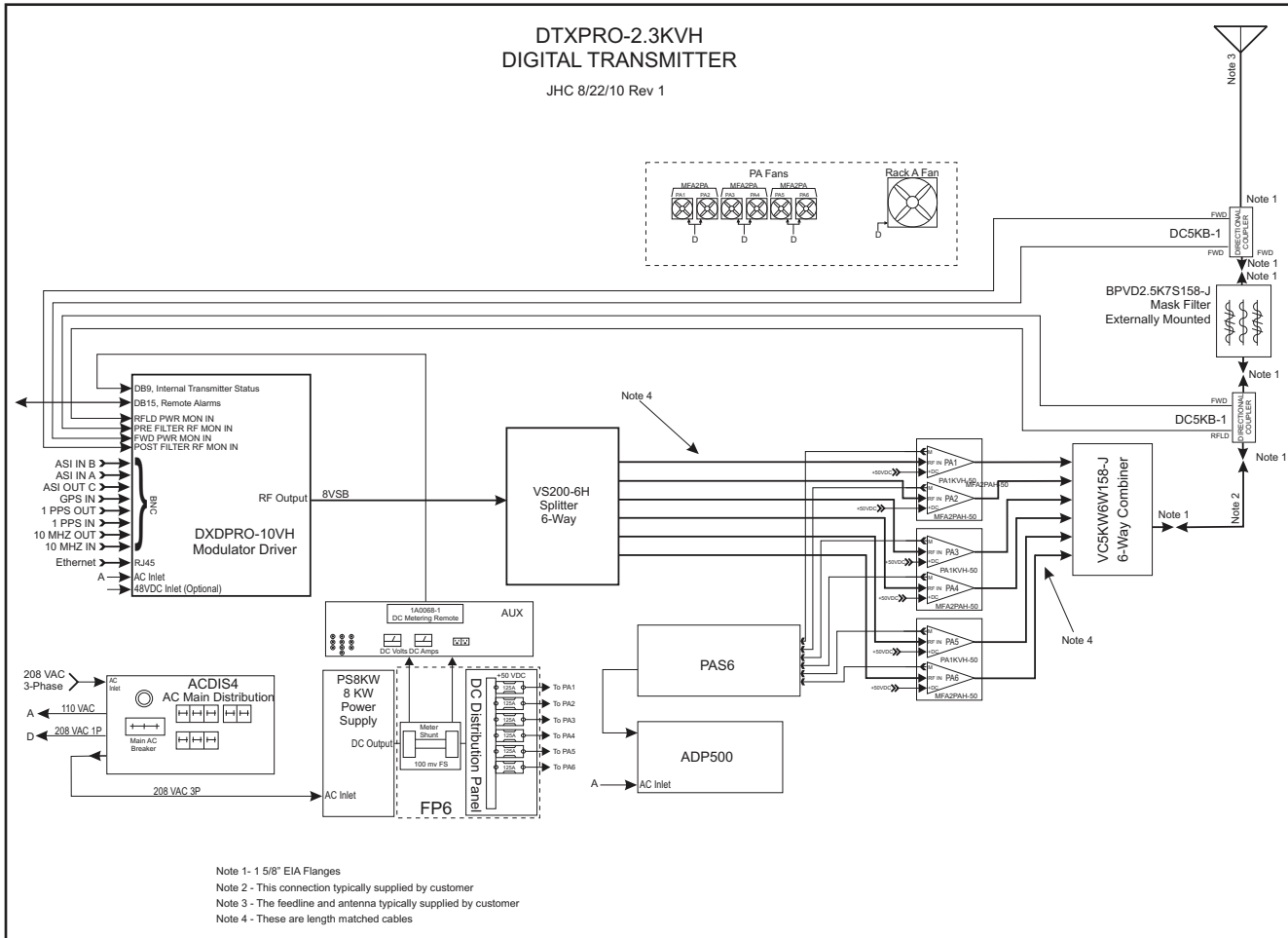

DTXPRO-2.3KVH UHF DIGITAL TRANSMITTER

BUILT IN DIGITAL MODULATOR
and TRANSMITTER REMOTE
CONTROL

MODULATOR DXDPRO-10VH FRONT PANEL

NOTE: Additional information available in the DXDPRO-10VH data sheet.

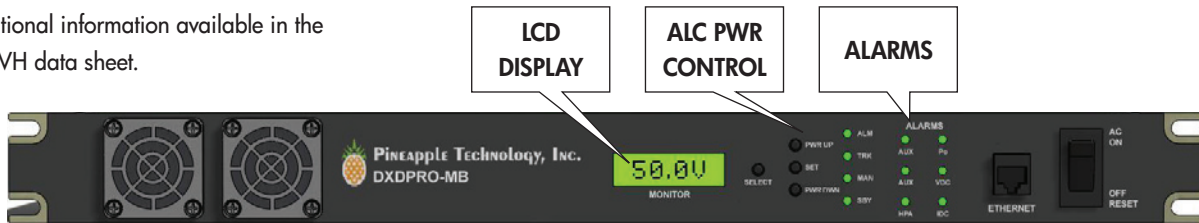

RECEIVER DISPLAY: The receiver control and display panel is used to show status of the receiver and allows selection of desired receive channel. The receiver signal strength is displayed as well as LOCK and POWER status.

LCD DISPLAY: The LCD DISPLAY provides selected transmitter test data by depressing the SELECT switch located on the right side. Some of the options include the following;

1. RF POWER OUTPUT LEVEL
2. REFLECTED POWER LEVEL
3. DC SUPPLY VOLTAGE
4. DC CURRENT

ALC CONTROL PANEL: The ALC section serves two important functions.

1. Provides a means for raising or lowering transmitter power level.
2. Once the desired power level is reached, the set switch places the ALC circuit in the TRACK MODE. In the TRACK MODE THE OUTPUT LEVEL IS CONSTANT.

ALARM PANEL: The alarm LEDs indicates status of key alarms. Key alarms include the following;

1. LOW OUTPUT POWERNORMAL (GREEN) FAULT (RED) <85 %
2. HIGH REFLECTED POWER.....NORMAL (GREEN) FAULT (RED) >20 %
3. 48 VDC SUPPLY.....NORMAL (GREEN) FAULT (RED) <42 v
4. AC MAIN VOLTAGE*NORMAL (GREEN) FAULT (RED) <50 %
5. AMBIENT TEMPERTURENORMAL (GREEN) FAULT (RED) >40 c
6. HEAT SINK TEMPERTURENORMAL (GREEN) FAULT (RED) >62 c

*48 VDC backup power required

REAR PANEL

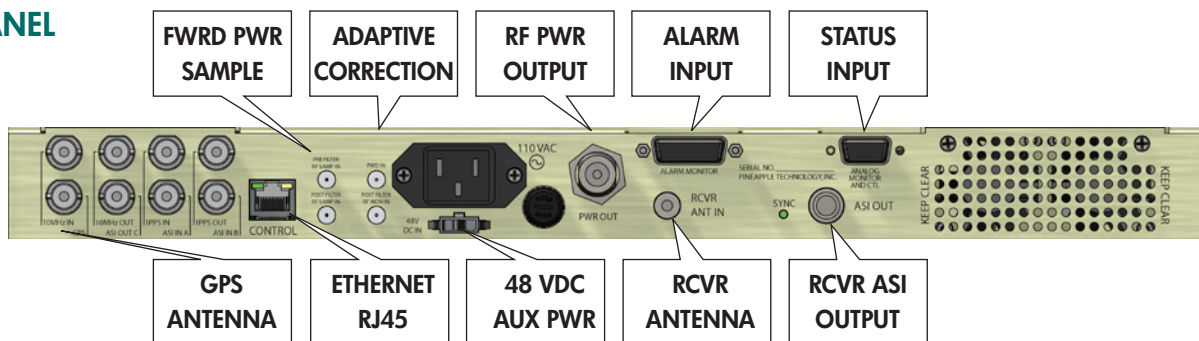

Mating Connectors

BNC JACK 75 OHMSGPS, ASI IN, SMPTE-310
ETHERNET RJ-45
RF MONITORING SMA JACK
ADAPTIVE SIGNAL..... SMA JACK
RF OUTPUT..... TYPE N JACK

RECEIVER ANTENNA..... TYPE F JACK
ALARM INPUTS..... DB 15 JACK
ANALOG STATUS DB 9 JACK
48 VDC INPUT..... MOLEX 3P

DTXPRO-2.3KVH UHF DIGITAL TRANSMITTER

BUILT IN DIGITAL MODULATOR
and TRANSMITTER REMOTE
CONTROL

WEB PAGE GUI

Web Page Commands

- Click and drag (XMTR ICON) to lower 1/2 page to see status and alarms
- Click and drag (LINEAR ICON) to lower 1/2 page to control linear correction
- Click and drag (NONLINEAR ICON) to lower 1/2 page to control nonlinear functions
- Click and drag (MUTE ICON) to lower 1/2 of page to mute and un mute xmtr
- Click and drag (RF OUTPUT) to change the output level from modulator
- Click and drag (BELL ICON) to view modulator alarms
- Click and drag (GPS ICON) to setup GPS receiver
- Click and drag (SWITCHING ICON) to select input port for ASI or SMPTE-310

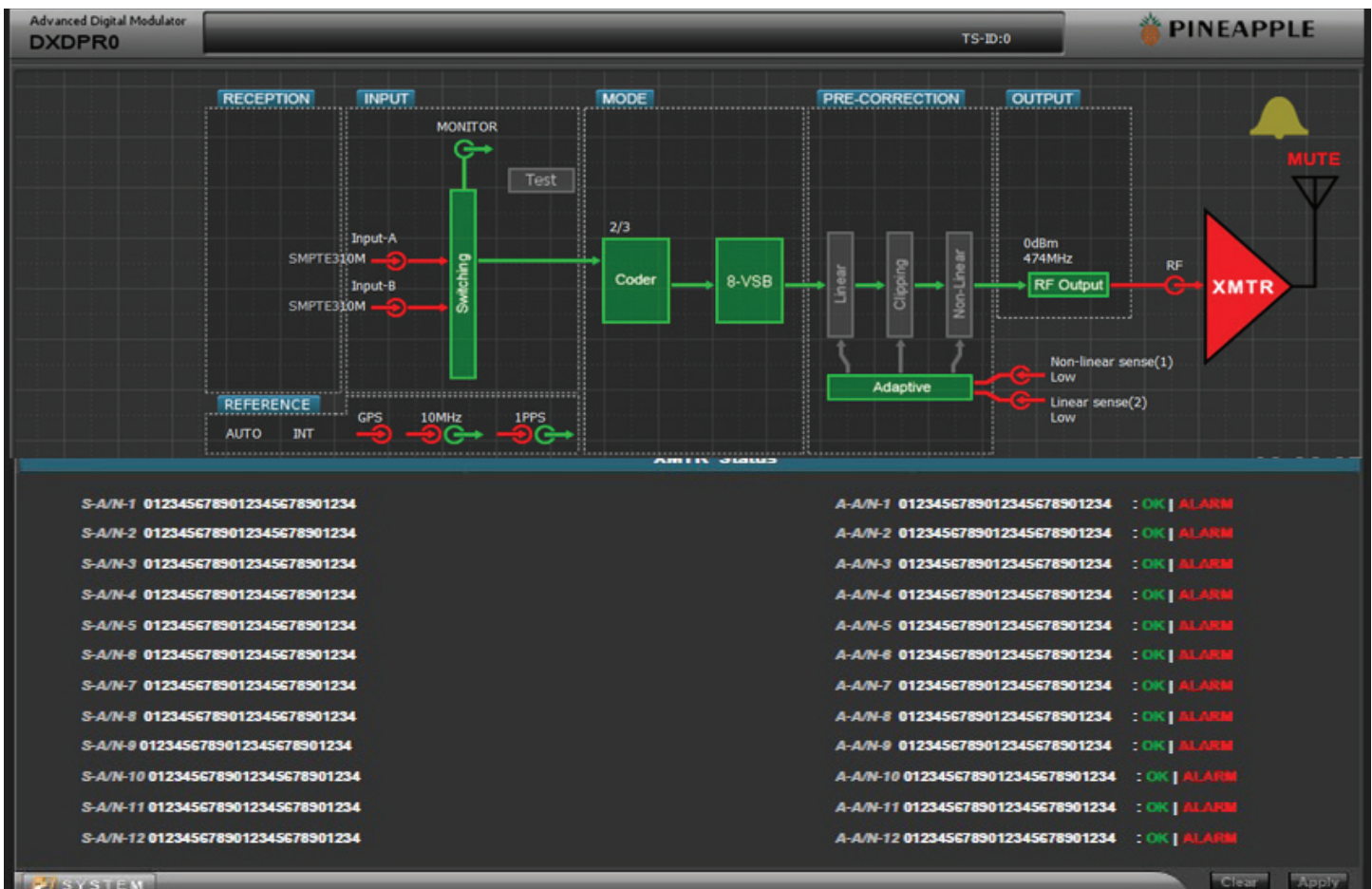

MFA2PAH FINAL AMPLIFIER (3/TRANSMITTER)

The final amplifier Mainframe includes the following items:

1. 2 EACH PA1KH-50
2. PA STATUS PANEL
3. COOLING FANS AND HEAT SINK
4. PA CURRENT STATUS MONITORING VIA DB-9
5. GAIN & PHASE MATCHING MODULE
6. ISOLATOR FOR EACH PA1KHU

MFA2PAH-50 BLOCK DIAGRAM

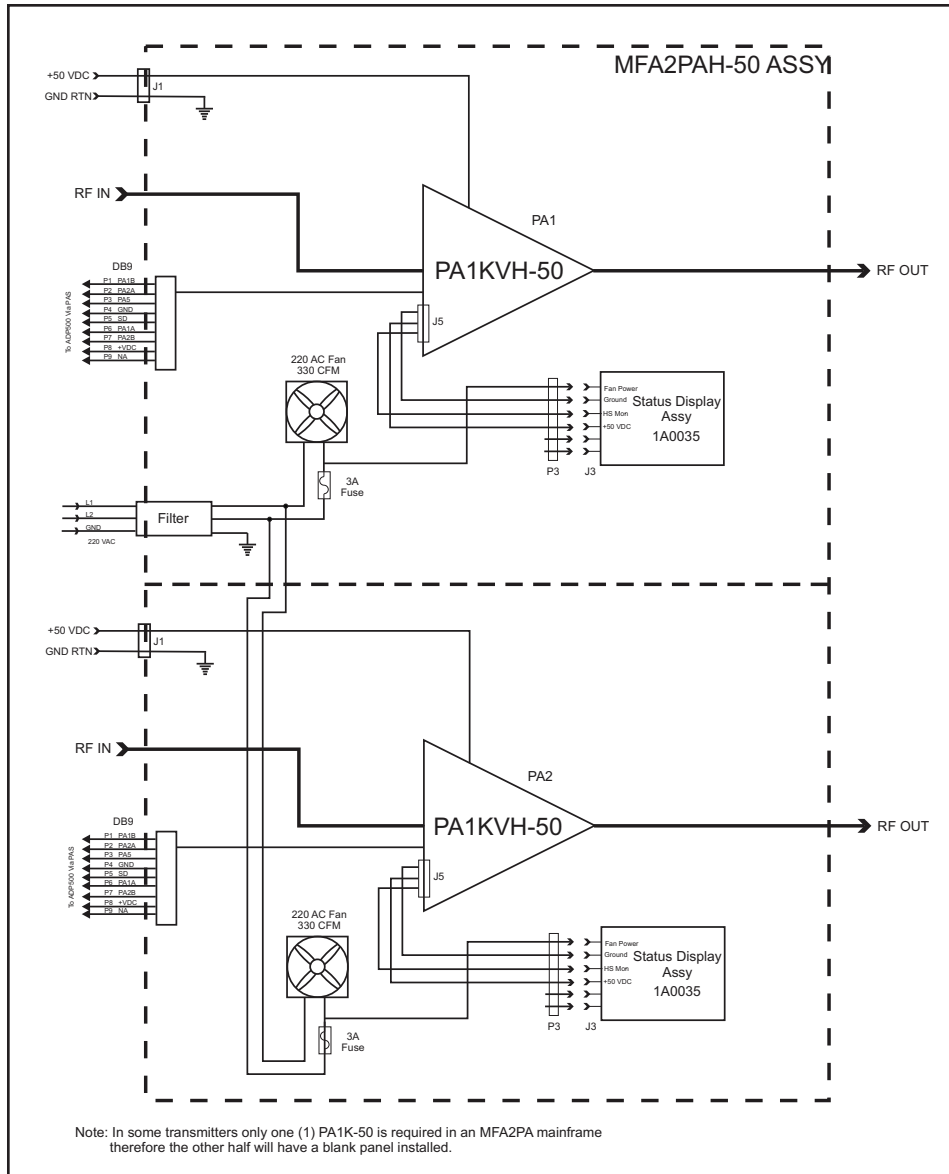

PINEAPPLE TECHNOLOGY, INC.

Web site: www.ptibroadcast.com

4231 Pacific Street, Suite 27, Rocklin, CA 95677

(916) 652-1116 . Fax: (916) 652-1161
U.S. Toll-free (888) 888-8229

ASSEMBLED IN U.S.A. Some products include foreign components.
Information contained herein is subject to change without notice.
© 2010 Pineapple Technology, Inc. All Rights Reserved. Rev. 10/6/2010